

UNI 5713 - DIN 6915
classe 10
UNI 5714 - DIN 6916
32 - 40 HRC

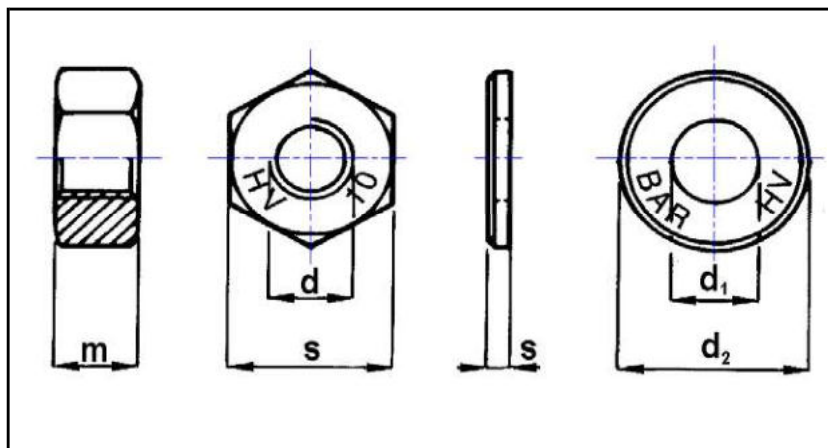

Dadi esagonali e rondelle per carpenteria

Dadi esagonali UNI 5713 **Zincati**

d	12	14	16	18	20	22	24	27	30
passo	1,75	2	2	2,5	2,5	2,5	3	3	3,5
s	22	24	27	30	32	36	41	46	50
m	10	11	13	15	16	18	19	22	24
euro x 100 pezzi	26,55	37,35	38,95	55,40	56,40	56,40	96,15	153,00	227,60

Rondelle UNI 5714 **Zincate**

d (vite)	12	14	16	18	20	22	24	27	30
d1	13	15	17	19	21	23	25	28	31
d2	24	28	30	34	37	39	44	50	56
s	3	4	4	4	4	4	4	5	5
euro x 100 pezzi	12,00	17,80	20,00	27,50	27,00	37,50	41,00	66,00	83,00