

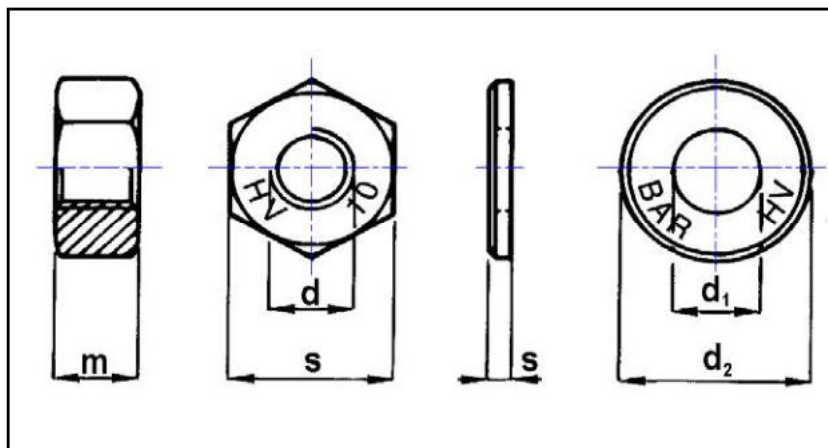

UNI 5713 - DIN 6915  
*classe 10*  
 UNI 5714 - DIN 6916  
 32 - 40 HRC



Dadi esagonali e rondelle per carpenteria

### Dadi esagonali UNI 5713

<b>d</b>	<b>12</b>	<b>14</b>	<b>16</b>	<b>18</b>	<b>20</b>	<b>22</b>	<b>24</b>	<b>27</b>	<b>30</b>
passo	1,75	2	2	2,5	2,5	2,5	3	3	3,5
s	22	24	27	30	32	36	41	46	50
m	10	11	13	15	16	18	19	22	24
euro x 100 pezzi	23,80	33,85	33,85	48,55	48,55	84,00	89,90	129,70	192,20

### Rondelle UNI 5714

<b>d (vite)</b>	<b>12</b>	<b>14</b>	<b>16</b>	<b>18</b>	<b>20</b>	<b>22</b>	<b>24</b>	<b>27</b>	<b>30</b>
d1	13	15	17	19	21	23	25	28	31
d2	24	28	30	34	37	39	44	50	56
s	3	4	4	4	4	4	4	5	5
euro x 100 pezzi	10,00	16,00	16,50	22,50	22,00	31,00	33,00	54,00	68,00